

1023201008

## EAPIR-8

EXIGO Alarm Panel, 8 buttons



### DESCRIPTION

- Network alarm panel for console mounting
- Communication and Power over Ethernet
- Eight programmable buttons with individual labels and status indicators
- Optional button protection covers
- LED Indicators for power, call, and fault
- For single or dual systems (A-B systems)
- Supports up to four EMBDR-8 button expansion modules
- The EAPIR-8 can not be an extension module for ECPiR-3P and ECPiR-1P

The EAPIR-8 is an alarm panel developed for console mounting and used with Exigo systems. The alarm panel features eight fully programmable buttons that can be used to manually initiate fire alarms, gas alarms, or any other action in the Exigo system apart from live speech and recall.

The alarm panel is fully digital, and connects to the Exigo system over standard Ethernet network cabling. Two monitored Ethernet ports are available in order to facilitate redundant cabling and connection to both the A and B system.

The alarm panel is fully monitored to ensure detection of any fault which may compromise the system's functionality.

LED indicators on the alarm panel show the status of the power supply and whether a fault is present in the system. The fault indicator can also be designated to only show faults on the access panel itself. Each of the access panel's buttons features two independent indicators that show the status of the button's function.

## SPECIFICATIONS

### MECHANICAL

|                     |   |
|---------------------|---|
| Dimensions (HxWxD): | 144 x 96 x 41.5 mm  |
| Weight:             | 500 g   |
| Mounting:           | Flush mount, in-console, desktop or on-wall (requires optional back box EMBR-1) |
| Color:              | Black   |

### ENVIRONMENTAL

|                        |                             |
|------------------------|-----------------------------|
| Operating temperature: | -10 °C to +60 °C            |
| Operating humidity:    | 10% to 95% (non-condensing) |
| Storage temperature:   | -40°C to +70°C              |
| Storage humidity:      | 10% to 95% (non-condensing) |
| Air pressure:          | 600 hPa to 1300 hPa         |
| IP rating:             | IP-32                       |

### ELECTRICAL

|                         |   |
|-------------------------|---|
| PoE:                    | 2 x RJ45, Mode A (in-line) or Mode B (spare pair) |
| Nominal voltage:        | According to IEEE 802.3af, class 0                |
| Auxiliary DC power:     | VNOM = 24 VDC, VMIN = 16 VDC, VMAX = 48 VDC       |
| Power consumption:      | PNOM ≤ 2 W (idle), PMAX = 8 W                     |
| Digital inputs/outputs: | 6 (configurable input/output/LED-driving)         |
| Relay outputs:          | 2 (250VAC/200VDC, 2A, 60W)                        |

### NETWORK

|          |  |
|----------|--|
| Ethernet | 2 x RJ45   |
|          | 10BASE-TX, 100BASE-TX, Auto negotiation, Auto MDIX |

### CERTIFICATIONS

|            |   |
|------------|---|
| Immunity:  | EN 60945, EN 50130-4, EN 61000-6-1, EN 61000-6-2, EN 55103-2, FCC-47 part 15B |
| Emissions: | EN 60945, EN 50130-4, EN 61000-6-3, EN 61000-6-4, EN 55103-1, FCC-47 part 15B |
| Safety:    | UL 60950-1, cUL 60950-1, CB to IEC 60950-1                                    |

## TECHNICAL DIMENSIONS

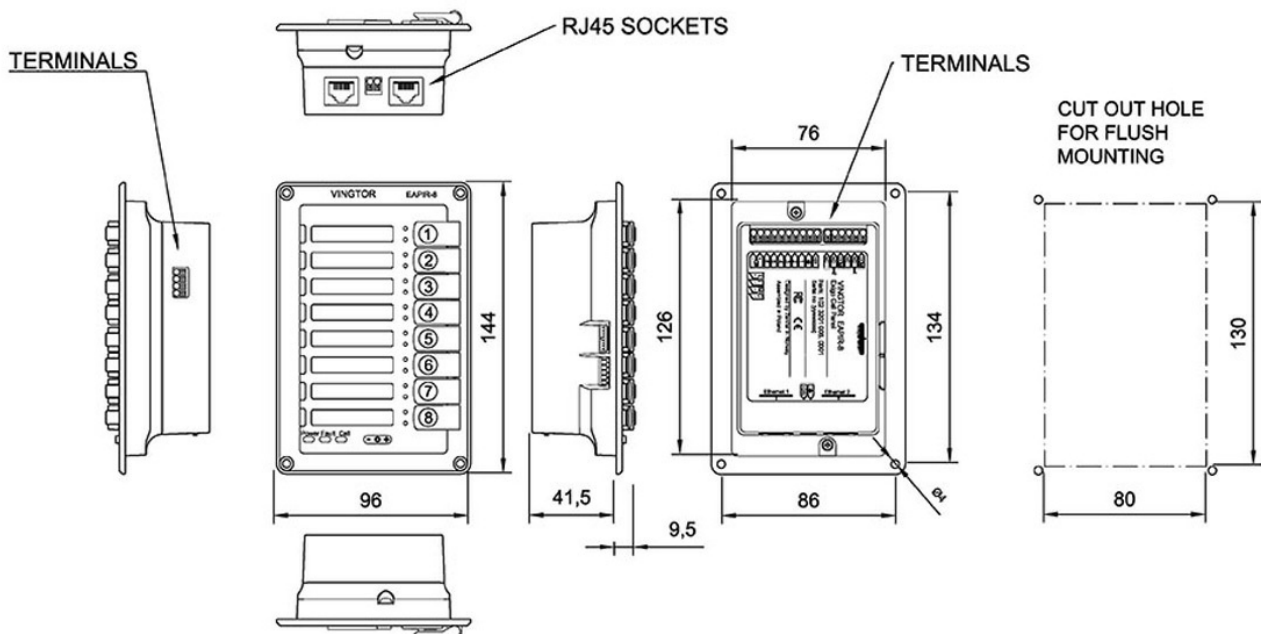

## ACCESSORIES



**EBMDR-8**

Item Number: 1023253008



**EMBR-2**

Item Number: 1023595020



**EMBR-1**

Item Number: 1023595010



**EPIPR-6**

Item Number: 1023697006