



YANMAR

MARINE DIESEL ENGINE

3YM27A

21.3kW (29PS)

MARINE PROPULSION DIESEL ENGINE FOR **LIFE BOAT**



Fresh water cooling with sea water cooled heat exchanger
用海水冷却式换热器进行淡水冷却



Keel cooling
用龙骨冷却器进行冷却

Photograph may show optional equipment.

Engine Specifications

Model	3YM27A	3YM27AK
Engine type	4-cycle water-cooled vertical diesel engine	
No. of cylinders, Bore × stroke	3 in line, 76×82	
Displacement	1.115	
Cont. rating Output (ISO8665-1)	19.4(26.4)	
Engine speed	3101	
Max. rating Output (ISO8665-1)	21.3(29.0)	
Engine speed	3200	
Direction of rotation	Anti-clockwise (View from stern)	
Propeller Shaft	Clockwise (View from stern)	
Cooling system	Fresh water cooling with sea water cooled heat exchanger	Keel cooling
Lubricating system	Pressure Lubrication with Trochoid Pump	
Starting system	Electric Motor	
Minimum battery capacity	12V, 96 (5h rate) Ah CCA 575A / JIS D 5301	
Length	715	690
Width	534	534
Height	649	575
Dry weight with KM2P-1	147	138

Marine Gear Specifications

Marine Gear Model	KM2P-1	
Type	Constant mesh gear with servo-cone clutch	
Reduction ratio	2.21/3.06, 2.62/3.06	
Direction of rotation	Clockwise (View from stern)	
Dry weight	9.8	

Dimensions (Unit : mm)

Fresh water cooling with sea water cooled heat exchanger. 用海水冷却式换热器进行淡水冷却

With KM2P-1 gearbox / Rear view

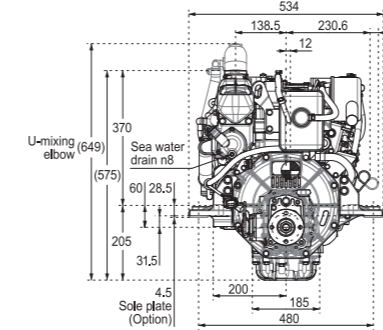

With KM2P-1 gearbox / Right side view

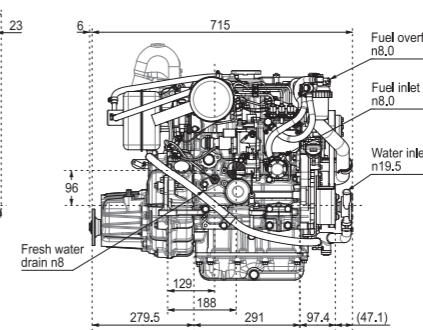

Keel cooling 用龙骨冷却器进行冷却

With KM2P-1 gearbox / Rear view

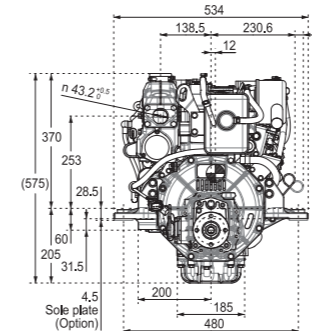

With KM2P-1 gearbox / Right side view

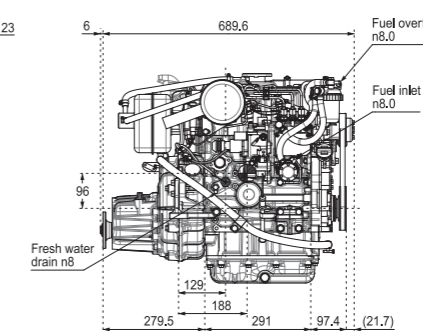

For engine installation, ask for the engine outline drawings. 安装时, 请另行索取装置外形图作为参考。

Note : 3YM27A do not comply with U.S. EPA emission standards and can not be used for an American flag vessel. 备注: 这个发动机不能满足美国EPA规则。禁止用于美国旗帜的船只。

主要数据

发动机名称	3YM27A	3YM27AK
形式	立式水冷4冲程柴油机	
汽缸数: 汽缸内径 × 行程	3 : 76×82	
总行程容积	1.115	
连续额定输出功率	19.4(26.4)	
旋转数	3101	
实用最大输出功率	21.3(29.0)	
旋转数	3200	
旋转方向	左(从船尾侧看)	
螺旋桨轴	右(从船尾侧看)	
冷却方式	间接清水冷却	龙骨冷却器冷却
润滑方式	通过强制润滑	
起动方式	电动式	
最小电池容量	12V, 96 (5h rate) Ah CCA 575A / JIS D 5301	
全长	715	690
外部尺寸 幅宽	534	534
全高	649	575
净重	147	138

船用齿轮规格

船用齿轮型号	KM2P-1	
形式	持续接触式齿轮箱, 自带离合器	
离合器减速比	2.21/3.06, 2.62/3.06	
旋转方向	右(从船尾侧看)	
净重	9.8	

Performance Curves

3YM27A

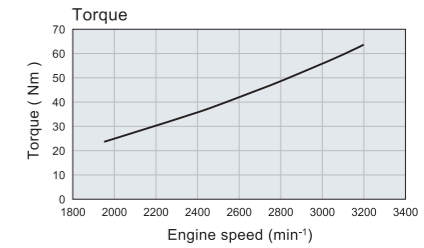
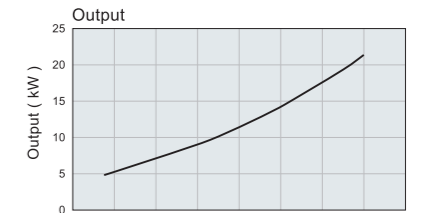
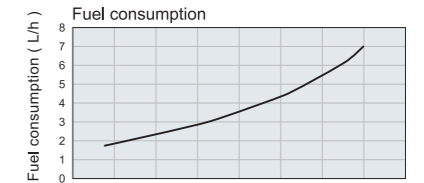

Rating definitions : hp=0.7355kW Ratings are based on conditions of 100kPa, 30% relative humidity at 25°C.
Fuel rates : Specific gravity 0.835g/cc, low calorific value 42700kJ/kg (10200kcal/kg), Cetane No.45.
额定定义: hp=0.7355kW 额定值是基于25°C时, 100kPa, 30%的相对湿度的条件
燃油比率: 比重0.835g/cc, 低热值42700kJ/kg的 (10200kcal/kg), 十六烷值45号

Mechanical Engine Control

SOLAS

29ps



- Read the operation manual carefully before use.
- Conduct all periodic checks to prevent breakdowns and accidents.
- Use only the fuel, lubrication oil, distilled water, etc., specified in the operation manual.
- Other types can cause breakdowns and accidents.
- Specifications and design in this catalogue are subject to change without notice.

- 请在仔细阅读使用说明书的基础上加以正确使用。
- 为了防止故障、事故发生于未然, 请务必进行定期检查。
- 请使用使用说明书中所指定的燃料、润滑油、清水等。
- 使用指定以外的产品, 可能会引发故障、事故。
- 本商品目录的规格以及尺寸图会因改良等发生变更, 但恕不事先通知。

YANMAR POWER TECHNOLOGY CO., LTD.

Large Power Products Business
1-1-1, Nagasu-Higashidori, Amagasaki, Hyogo, Japan
Tel : +81-6489-8069 Fax : +81-6489-1082
yanmar.com

Note : All Data Subject to Change Without Notice.

YANMAR, Providing Quality Propulsion Engine Packages for Over 60 Years.

Operation side 操作侧

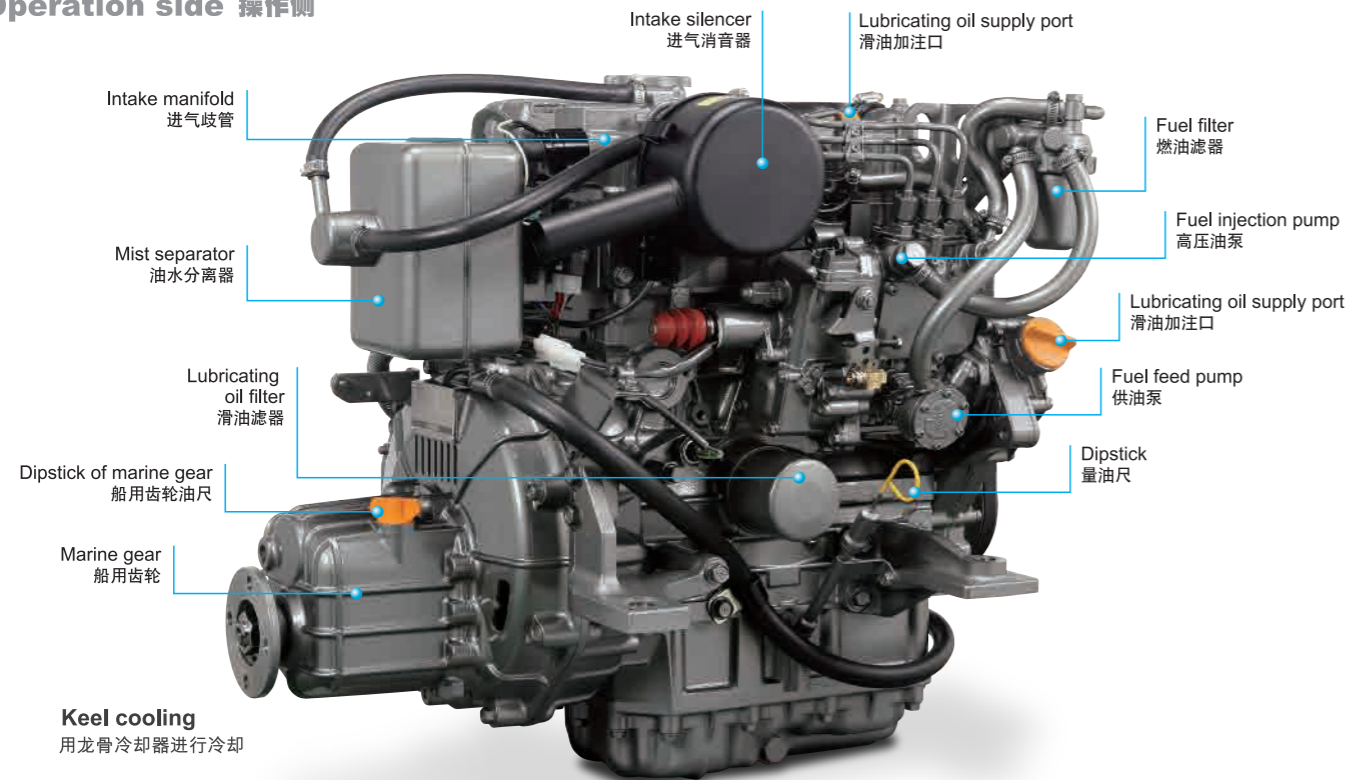

Non operation side 非操作侧

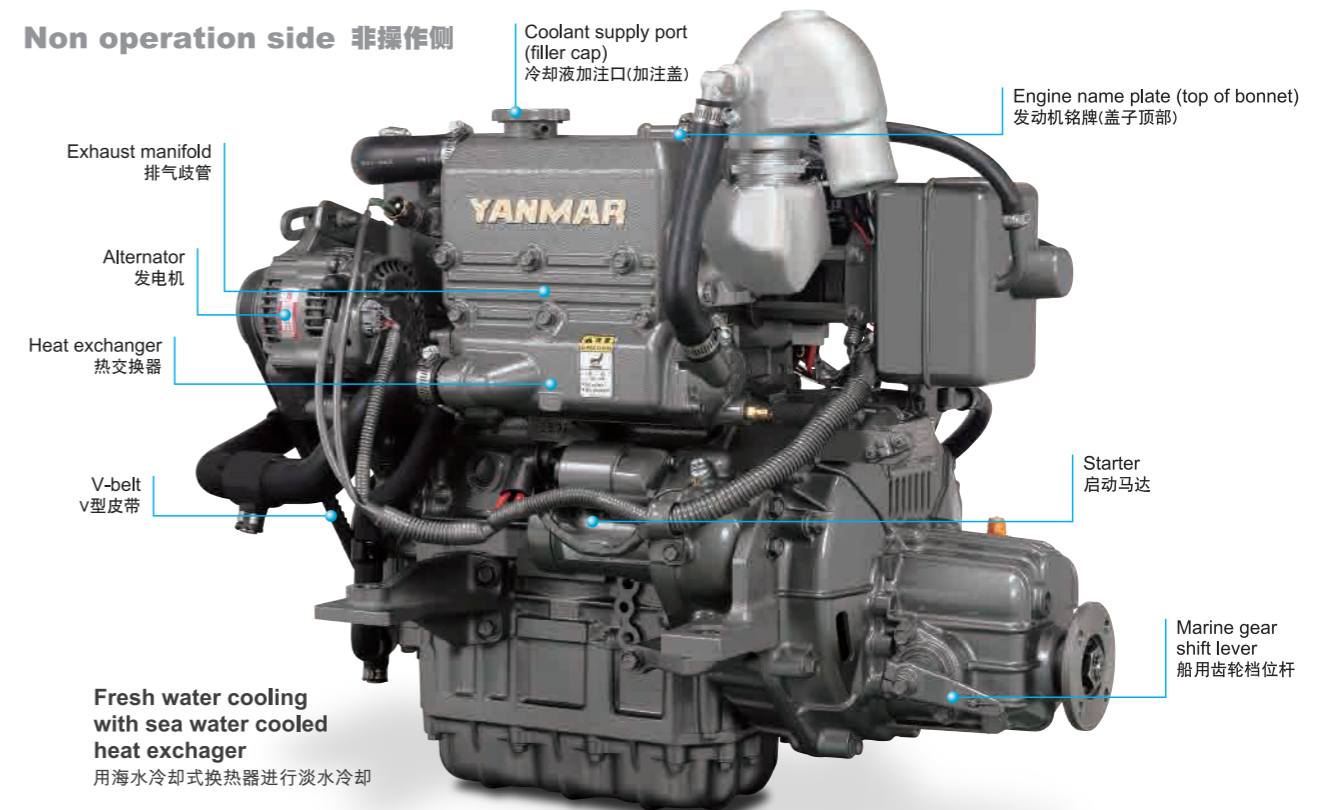

Photograph may show optional equipment.

A FULL SCORE IN "SOLAS"

Clears requirements set forth by the SOLAS Convention.

Yanmar's 3YM27A Propulsion engines for lifeboats meet the newest SOLAS requirements. The engine clears all requirements set forth by the SOLAS convention (LSA code) and conforms to the Marine Equipment Directive (MED: Council Directive 96/98EC on Marine Equipment).

完全符合SOLAS条约的必要条件

洋马救生艇用主机3YM27A是一款100%符合SOLAS条约的LSA规则必要条件的发动机。还符合船舶用指令(MED)96/98EC。发挥洋马的技术与经验,以卓越的操作性、保养性为豪。

Free-fall Life Boat

Complies with the stricter requirements placed on free-fall lifeboats by the revised SOLAS III/31 that had gone into effect on July 1, 2006. For free-fall life boat, choose a keel cooling specification engine.

对应自由下降式救生艇。

还对应2006年7月1日发布的自由下降式救生艇执行强制化的修正SOLAS III/31规则。



Keel Cooler

We have the keel-cooling system which is cooled the fresh water of circulation pump only for keel-cooling.



还可满足对龙骨冷却规格的要求。

我们还有龙骨冷却器规格的产品,适合采用龙骨冷却器冷却方式的清水1系统冷却。

Even a 360° Roll

Won't Stop the Engine!

Even when the boat turns upside down, the engine keeps on running continuously at the rated engine speed through a 360° roll. The secret is the midjet mist separator.

即使旋转360°,也可以正常运转。

装有小型湿气分离器。在额定运转状态下,360°反转复原后,也可无异常继续运转。

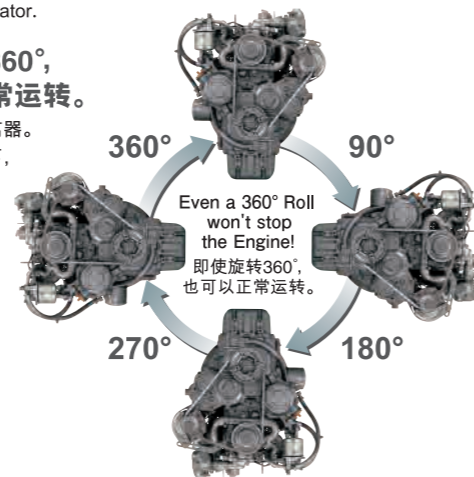

Five Minutes More without Secondary Cooling Water!

The engine can idle for five minutes without the use of secondary cooling (sea) water. ※To conduct an on-board test on the freshwater & seawater dual cooling system, supply water from the ship to run it.

即使没有2次冷却水,也可运转5分钟。

在没有2次冷却水(海水)的状态下,可以持续5分钟的惰转。 ※采用清水/海水冷却方式时,在船上的检查请通过船舶供水并进行运转。

Underwater Operation!

Even when the engine is submerged in water up to the center line of the crankshaft, the engine can run at the rated speed for at least 5 minutes.

也可以进行浸水运转。

即使浸水到曲柄轴中心线的高度,也可以保持5分钟以上的额定旋转正常运转。

Designed to Withstand a 30m Fall!

The results of the free-fall height in lifeboat.

Fitted on a lifeboat and dropped from a height of 30m into the water, there is no change in engine performance.

采用适应从水面上30m落下的设计。

在安装到救生艇的状态下,即使从距水面30m的位置落下,其性能、功能也不会出现异常。 ※使用自由下降式救生艇的实际高度

Starting at -25°C! with block heater(option)

The engine starts reliably within two minutes at -15°C with glow plug.

即使在室温-25°C时也可以起动。

采用电动起动方式时,即使在室温-15°C的状态下,也可以在2分钟内顺利起动。

Instrument panel

The formats for the instrument panel are shown below.

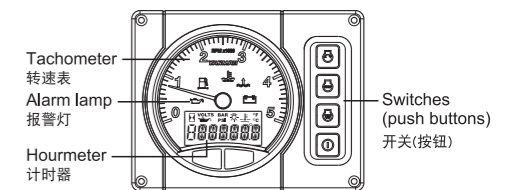

仪表盘格式

仪表盘格式如下图所示。

Control panel switches 控制面板开关

All switches are push-buttons. 所有开关都是按钮。

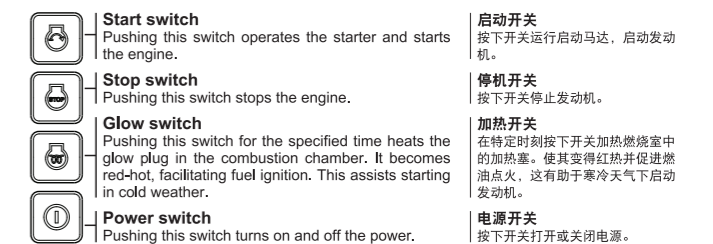

Warning Devices 报警装置

With the exception of the charge lamp, warning lamps will light up and the alarm buzzer will sound at the same time to indicate a problem.

除了充电指示灯,报警指示灯会亮起时,蜂鸣器同时会响起,提示有故障。

