

SHINKO

DEEPWELL CARGO PUMPS
FOR LIQUEFIED GAS CARRIERS
STN

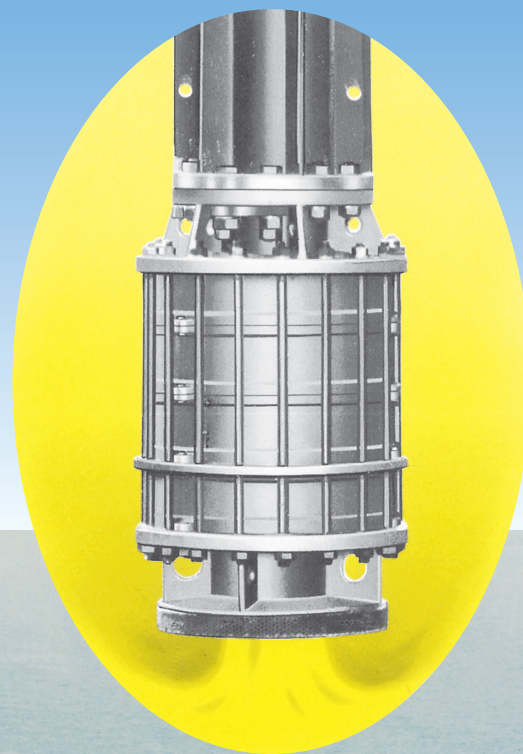

STN DEEPWELL CARGO PUMPS

Shinko STN deepwell centrifugal pumps have been designed and manufactured as cargo pumps for liquefied gas such as LPG, liquefied ammonia, vinyl chloride monomer, ethylene, etc. It has the following features:

- The prime mover is installed on top of the cargo tank and the impellers are submerged in the liquid which is driven through the long intermediate shaft. Therefore, priming equipment is unnecessary.
- As it is a multi-stage pump, any head can be applied by changing the number of stages.
- The inducer has excellent suction performance at the bottom end. Thus, it can reduce the residual liquid to a minimum.
- The discharge pipe is used as support for the casing and intermediate shaft. Hence, extra piping in tank is unnecessary, reducing the setup cost.
- Our most reliable mechanical seal has been equipped as the stuffing box seal. It can be replaced safely and easily without removing the pump from the tank, even if the mechanical seal is damaged.
- For the prime mover, a pressure-resistant and explosion-proof motor is employed.



■ GENERAL CHARACTERISTICS

Item \ Model	STN 125	STN 150	STN 200	STN 202
Type	Deepwell multi-stage type with inducer			
Handling liquid	LPG. Liquefied ammonia. VCM. Ethylene			
Liquid temperature (°C)	-110~+45			
Number of stages	4, 5, 6	3, 4, 5	3, 4, 5	3, 4, 5
Speed (min ⁻¹)	1750			
Discharge bore (mm)	125	150	200	200
Direction of rotation	Clockwise when viewed from the prime mover			
Thrust bearing	Ball bearing			
Lubrication	Grease			
Stuffing box seal	Mechanical seal			

PERFORMANCE CHART

Ethylene
SG : 0.57

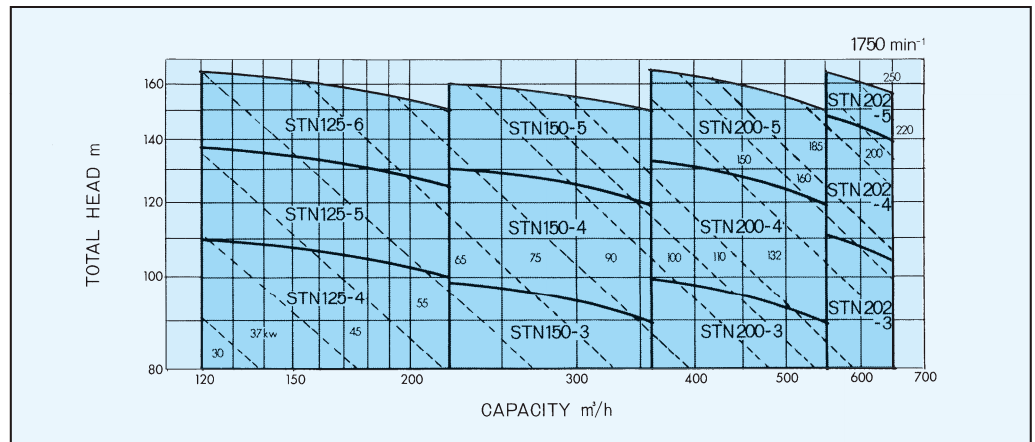

Propane, Butane
SG : 0.61

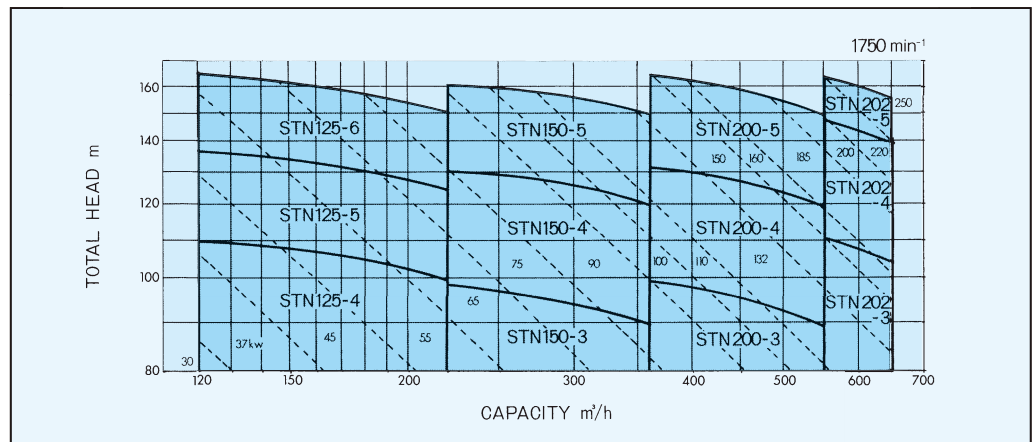

Butadiene, Ammonia
SG : 0.65

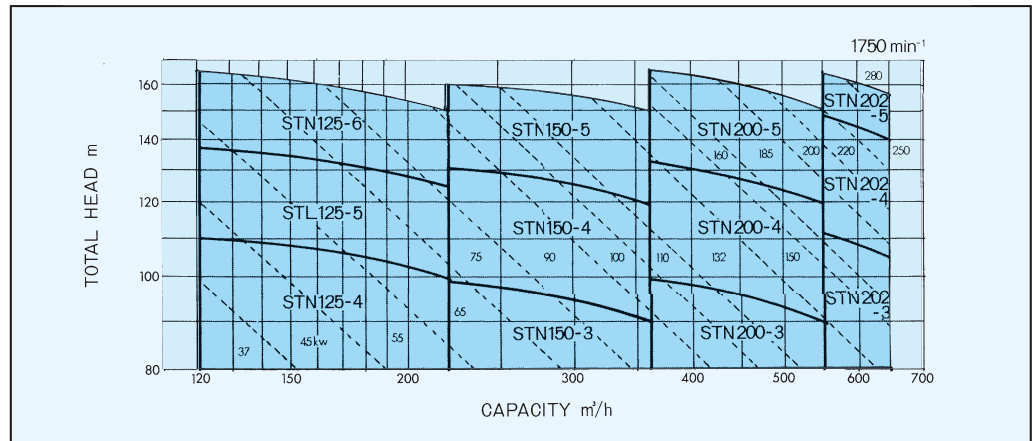

VCM
SG : 0.94

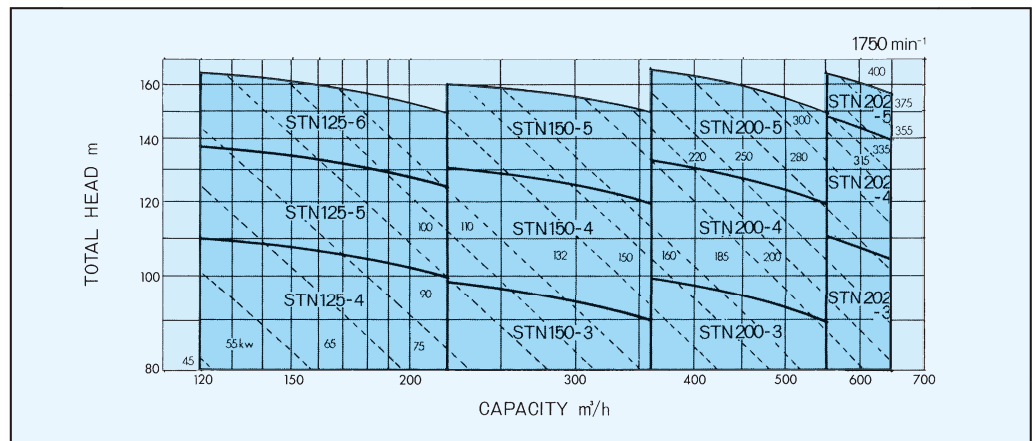

DESIGN & MATERIALS

The pump casing is attached to the bottom end of the long discharge pipe. And, the impellers are driven through a long intermediate shaft, which is supported by submerged line bearings.

At the pump inlet, an inducer is equipped in order to improve the suction performance and a mechanical seal is utilized where the shaft passes through a casing of the pump support.

As the pump is equipped with a split discharge pipe, it is possible to carry out maintenance in the tank without lifting out the pump.

The following table should be referred to when handling liquids at temperature between -110°C and -10°C . When handling liquids above -10°C , the following materials must be changed:

Suction casing, stage casing, and inducer	: Ductile cast iron (FCD600)
Volute and impeller	: Cast iron (FC200)
Pump support	: Cast steel (SC450)
Discharge pipe	: Steel (SGP)
Shaft	: Stainless steel (SUS 403)

PART NO.	NAME OF PART	REQ. NO FOR 1PUMP	MATERIAL		
			NAME	JIS	ASTM EQUIVALENT
1	SUCTION CASING	1	STAINLESS STEEL	SCS13	A296-77 CF 8
2	VOLUTE		〃	〃	〃
3	STAGE CASING		〃	〃	〃
4	DISCHARGE CASING	1	〃	〃	〃
5	PUMP SUPPORT	1	〃	〃	〃
6	MOTOR BED	1	STEEL	SS400	A6-71
7	DISCHARGE PIPE		STAINLESS STEEL	SUS304L	A276-77 304L
8	BEARING HOUSING	1	CAST IRON	FC200	A48-76
15	INDUCER	1	STAINLESS STEEL	SCS13	A296-77 CF 8
16	IMPELLER		〃	〃	〃
18	SHAFT		〃	SUS304	A276-77 304
22A	SLEEVE		〃	〃	〃
22B	SLEEVE		〃	〃	〃
23	BALANCE BUSH	1	SPECIAL CARBON		
24	BALANCE PISTON	1	STAINLESS STEEL	SUS304	A276-77 304
35	BALL BEARING	1	SPECIAL STEEL		
38	MOUTH RING		SPECIAL CARBON		
41	LINE BEARING		〃		
42	LINE BEARING		〃		
49	COUPLING	1	STAINLESS STEEL	SUS304	A276-77 304
50	COUPLING	1	DUCTILE CAST IRON	FCD400	A536-77 60-40-18
50A	SPACER COUPLING	1	〃	〃	〃
52	SLEEVE COUPLING		STAINLESS STEEL	SUS304	A276-77 304
53	ADJUSTING NUT	1	STEEL	SS400	A6-71
54	MECHANICAL SEAL	1 SET	STAINLESS STEEL	SUS316	A276-77 316

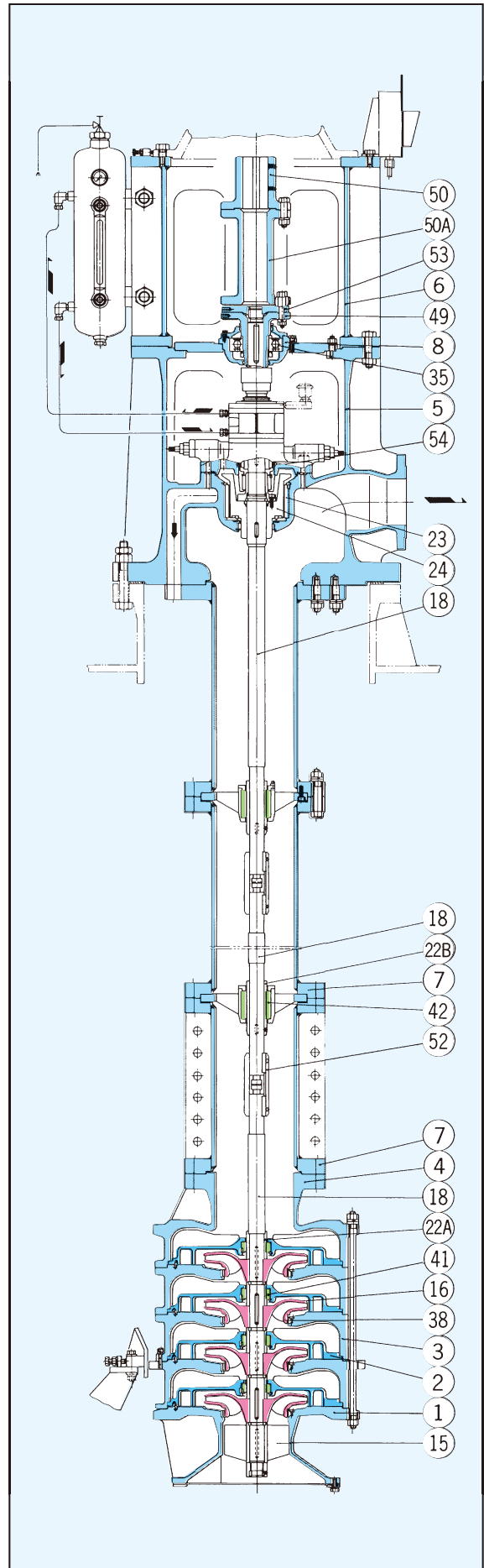

● Pump Casing

The pump casing has quadruple chambers, consisting of several volutes, stage casings, and a discharge casing, where the kinetic energy of the handling liquid discharged from the impellers is converted into the pressure energy.

The pressure induced on the exterior of the impellers is distributed symmetrically to the shaft center. The radial thrust acting on the impellers is balanced at each stage. And, no shaft deflection occurs in any operating ranges.

As the volute is an open type, internal finishing, cleaning, and inspection can be carried out easily. And, it can be assembled inside the stage casing.

Each stage casing is tightened with rigid bolts along with a suction cover and a discharge casing.

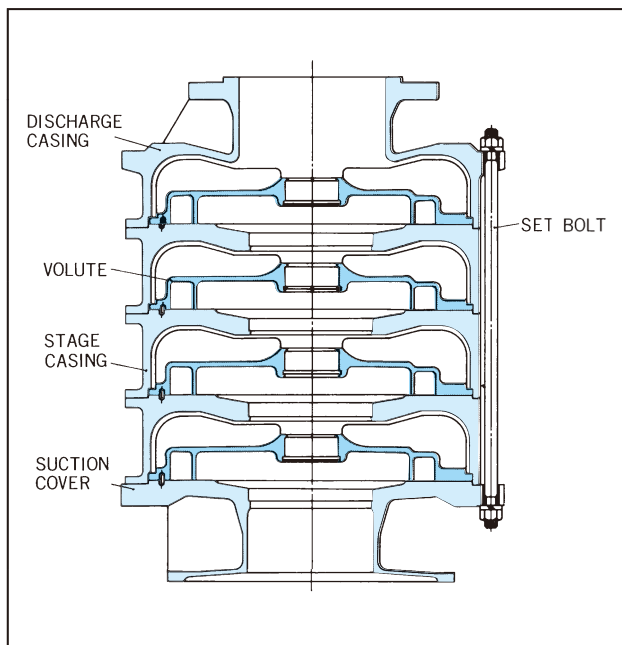

● Inducer

To minimize the NPSH level of the pump, an inducer is employed at the inlet of the 1st stage impeller.

The inducer is a booster, having two spiral blades, improves suction performance.

● Impeller

The impellers are a single suction type. And, the inside passages are finished with great care to improve pump efficiency.

The impellers are located on the shaft and firmly secured by means of keys, sleeves, and split rings. Hence, the shaft does not bend and is free from axial expansion and shrinkage.

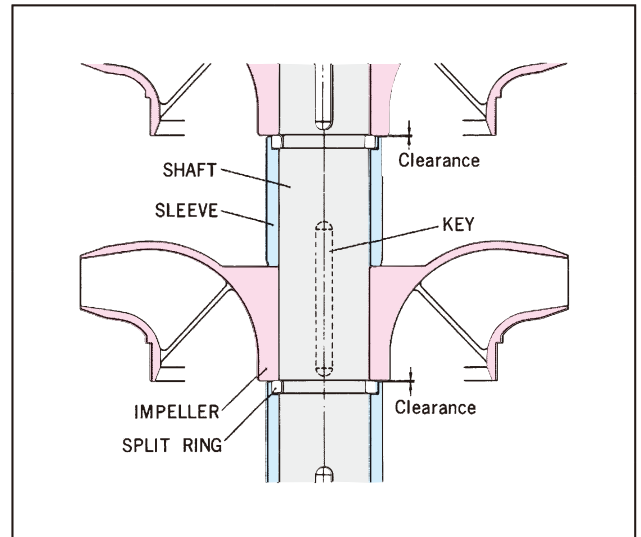

● Balance Piston

In order to balance the downward thrust that occurs on the impellers, a balance piston acting against the discharge pressure is employed on the upper side of the pump.

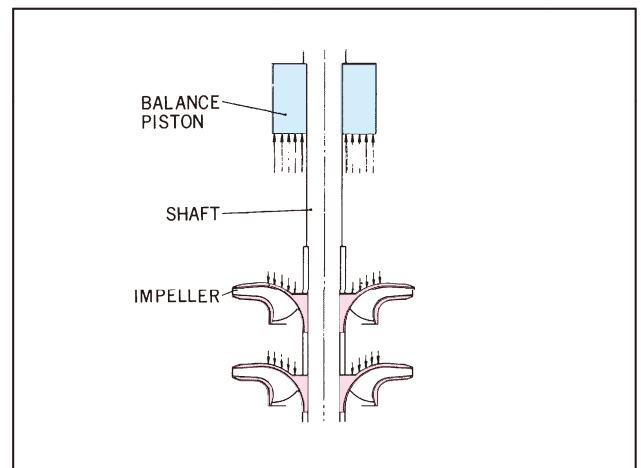

●Thrust Bearing

A single row deep groove ball bearing (63 type), having sufficiently long service life, is fitted on the upper side of the pump.

As the grease-sealed ball bearing is used, it is not necessary to pour out the grease. And, the pump can be maintained easily.

●Line Bearing

Line bearings are used in the pump casings and in the discharge pipes as radial bearings, and they are lubricated by the handling liquid.

Generally, the handling liquid tends to achieve lower lubricating performance in the case of low viscosity. For this reason, special high wear-resisting carbon is employed as material for the bearings. Therefore, the dry running is possible during the stripping process.

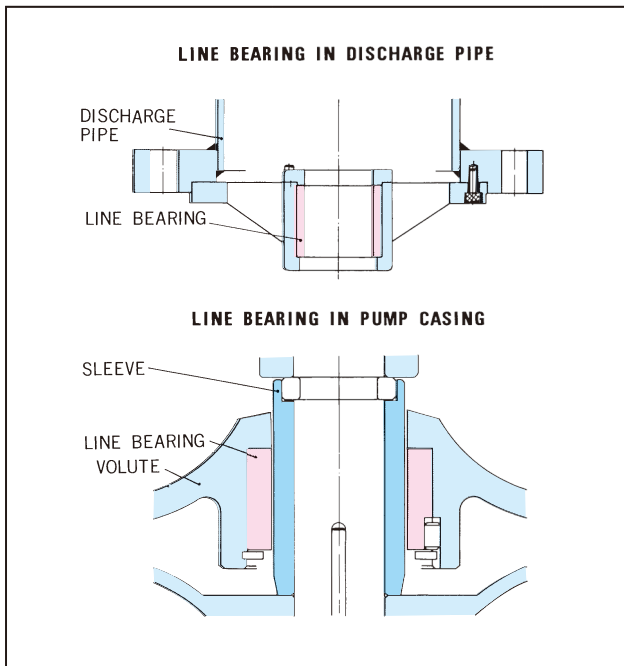

●Stuffing Box Seal

A reliable mechanical seal has been attached to the stuffing box.

It is quite difficult to completely prevent leakage from the mating face when a single mechanical seal is fitted in the pump while handling liquefied gas. Therefore, double mechanical seals have been equipped to stop the liquefied gas from leaking into the atmosphere directly through the seals.

The gas leaked from the lower seal is gathered into the oil tank through the upper seal box and the cooling tube, and then is released into the atmosphere in

a safe location.

When it is necessary to inspect or replace the seal, the following method should be carried out:

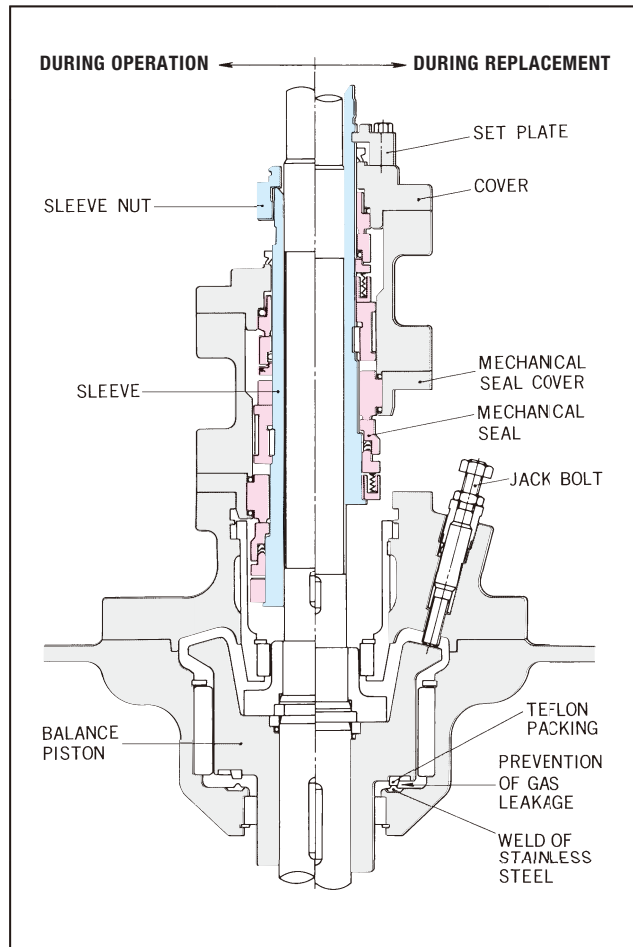

- (1) Left and right side of the figure above show conditions during normal operation and during replacement of the seal. First, the balance piston is pushed down by tightening the jack bolt to prevent gas leakage from the tank.
- (2) After removing the spacer coupling, the pump-side coupling can be removed along with the ball bearing and the bearing housing.
- (3) Next, the mechanical seal can be pulled out along with the sleeve after removing the sleeve nut.
- (4) The seal can be reassembled by following these steps in reverse order. The mechanical seal can be fastened properly by attaching the sleeve with the set plate.

● Stuffing Box Seal Customized for Cryogenic Liquid (Option)

When handling liquid at temperatures of about -100°C , it is quite difficult to keep the temperature of the stuffing box the same as the handling liquid since there is such a big temperature difference with the atmosphere.

Ethylene can be explosive when it becomes the mixed with oxygen at a rate of 1 part oxygen to 2 parts ethylene. Therefore, leakage of these liquids must be avoided at all costs.

With consideration to the above, the stuffing box seal of the cargo pump, which handles the cryogenic liquid, has the following design:

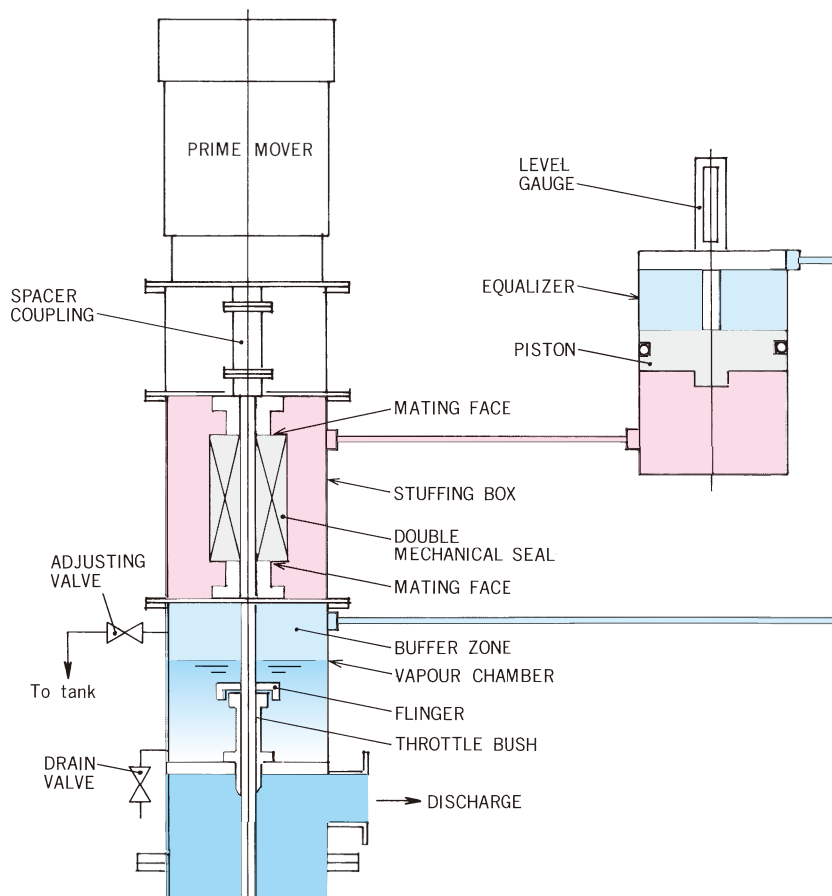

1. A large vapour chamber is located between the pump case and the stuffing box. The upper part of the vapour chamber is designed as a buffer zone and a double mechanical seal has been equipped at the stuffing box.
2. Refrigerating machine oil or methanol is used as a sealing liquid for the double mechanical seal. Pressure in the buffer zone is added to the sealing liquid via an equalizer which has a piston and is able to adjust to the variation in pressure in the buffer zone, and continuously applies a slightly higher pressure to the stuffing box side, consequently preventing any gas leakage. When operating the pump in a cold zone, heating is applied to the stuffing box.
3. To detect abnormal seal liquid leakage, the following measures are taken:
 - a. When the leak comes from the upper mating face of the double mechanical seal, the piston in the equalizer descends, and the conditions can be judged by the level gauged attached to the equalizer.
 - b. When the leak comes from the lower mating face of the double mechanical seal, sealing liquid enters the vapour chamber and the piston equalizer descends from the loss of sealing liquid, and the conditions can also be judged by the level gauge. The flinger is equipped to prevent the leaked sealing liquid from entering from the pump side.

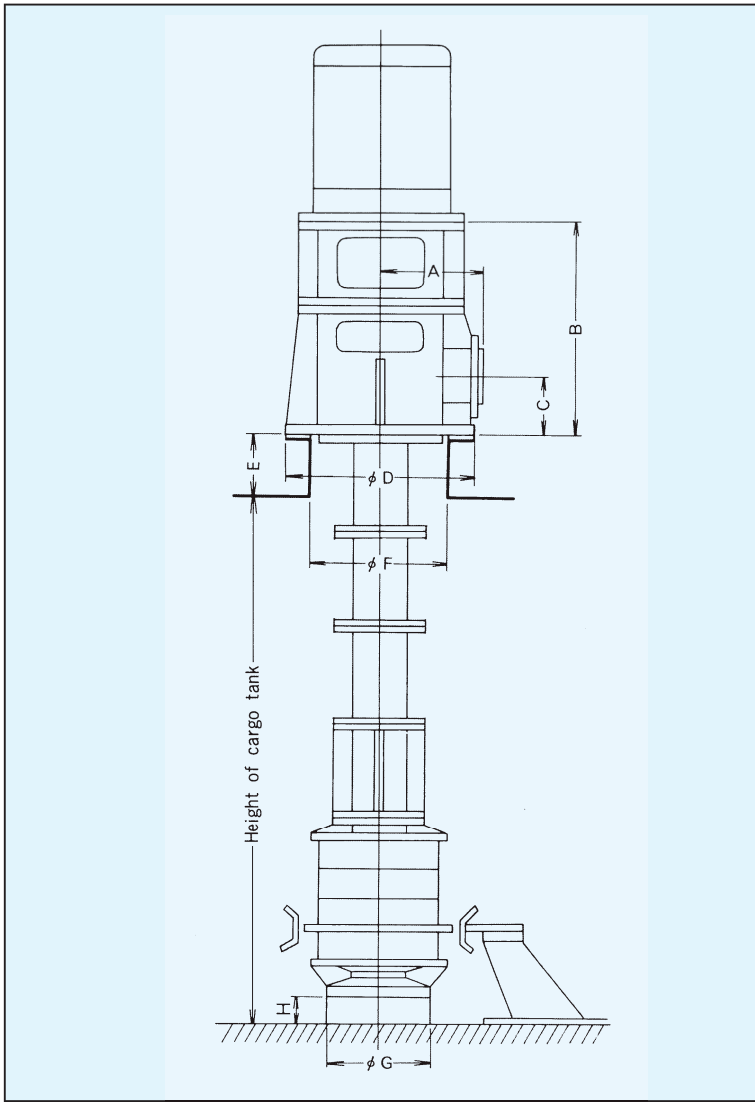

Dimensions : mm

Model	A	B	C	D	E	F	G	H
STN 125	480	1330	260	925	330	700	450	45
STN 150	480	1330	260	925	330	700	600	55
STN 200	515	1360	260	925	330	700	650	70
STN 202	515	1390	260	925	330	740	700	85



SHINKO IND. LTD.

Head Office & Factory

5-7-21, Ohzu, Minami-ku, Hiroshima, Japan

TEL81-82-508-1000

FAX81-82-508-1020

Tokyo Office

1st Floor, 6-1-8, Kitashinagawa, Shinagawa-ku, Tokyo, Japan

TEL81-3-3441-6221

FAX81-3-5488-7370

Kobe Office

3-1-16, Nakamachidori, Chuo-ku, Kobe, Japan

TEL81-78-341-0919

FAX81-78-366-2027

Shinko Machineries Europe B.V.

Rembrandt Bldg., Biesbosch 225, 1181 JC Amstelveen, The Netherlands

TEL31-20-6477053

FAX31-20-6475633

Bangkok Representative Office

c/o NSK Energy Co., Ltd. 12th Floor, Amarin Tower 500 Ploenchit Road Pathumwan Bangkok 10330, Thailand

TEL66-2256-9134

FAX66-2256-9167

Singapore Representative Office

c/o Fujii Horiguchi Engineering PTE LTD. 24 Chia Ping Road Singapore 619976

TEL65-6265-1089

FAX65-6863-8310

Shanghai Representative Office

Rm1421, 14Floor, Yuandong Mansion No. 1101 Pudong South Rd, Pudong New Area Shanghai 200120, China

TEL86-21-5876-1080

FAX86-21-5876-1079

Doha Representative Office

c/o Middle East Fuji LLC-Qatar (Doha Office) P. O. Box. 205078, Doha Qatar Salwa Road, Back of Bukanan Furniture, Aljazeera Complex, Retaj Building, B1 Entrance, 1st Floor, Office No. 120, Doha, Qatar

TEL974-4443-1131

FAX974-4443-1131