

SOUND POWERED TELEPHONE SYSTEMS

TELEPHONES

TYPE: SCM-TA-MG

MODEL: TA-4CI-MG-24

(Telephone 24 Ext. with shock and vibration isolation)

SCM
SISTEMAS



FEATURES

- Excellent speech quality.
- 24 extensions selector switch.
- For use on open air deck areas and bridge wings.
- Material: ABS polymer (fireproof).
- Earpiece: ABS polymer (fireproof)
Spiral cord (60 cm extensible to 1.5 m).
- Available headphone connection for noisy areas:
Model: TA-ACM-A.
- Optional acoustic/luminous alarm via relay box.
- Includes metallic cableglands and springs.
- Other features: earpiece-lock system.
- Includes dampers (VIBCABLE V3CA8010 series)
 - High deflection in all directions
 - Natural frequency between 5 Hz /25 Hz
 - Compliant with MIL-STD-167

TECHNICAL SPECIFICATIONS

Operating temperature	-20°C to +50°C
Acoustic alarm	80 dB(A) (1m)
Relative humidity	Up to 95% (non condensing)
Assembly	Bulkhead
Weight	Approx 2 kg
IP-rating	66
Resistive load	10A 250VAC / 30VDC
Inductive load	($\cos\phi = 0.4$; L/R = 7 ms) 5A250VAC / 30VDC

SOUND POWERED TELEPHONE SYSTEMS

TELEPHONES

TYPE: SCM-TA-MG

MODEL: TA-4CI-MG-24

(Telephone 24 Ext. with shock and vibration isolation)

SCM
SISTEMAS

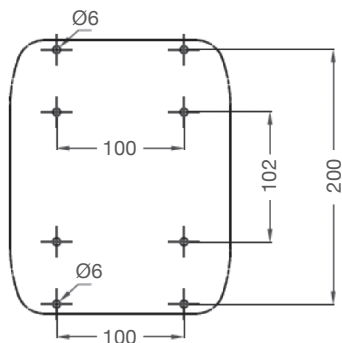
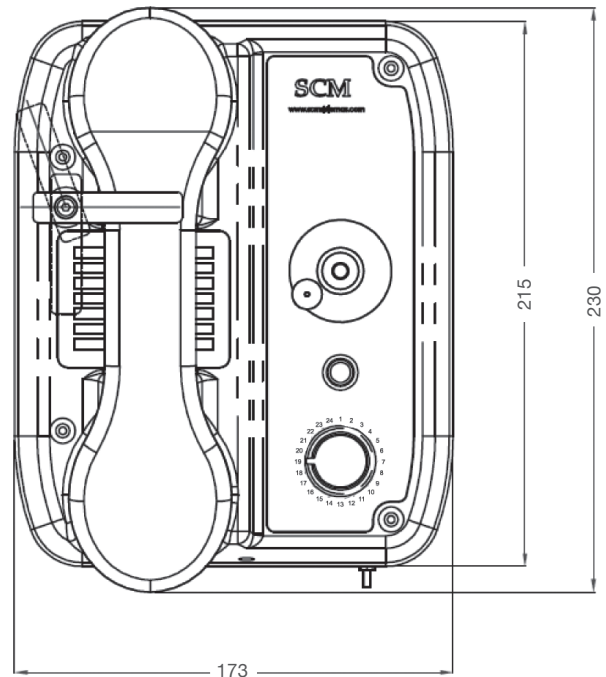
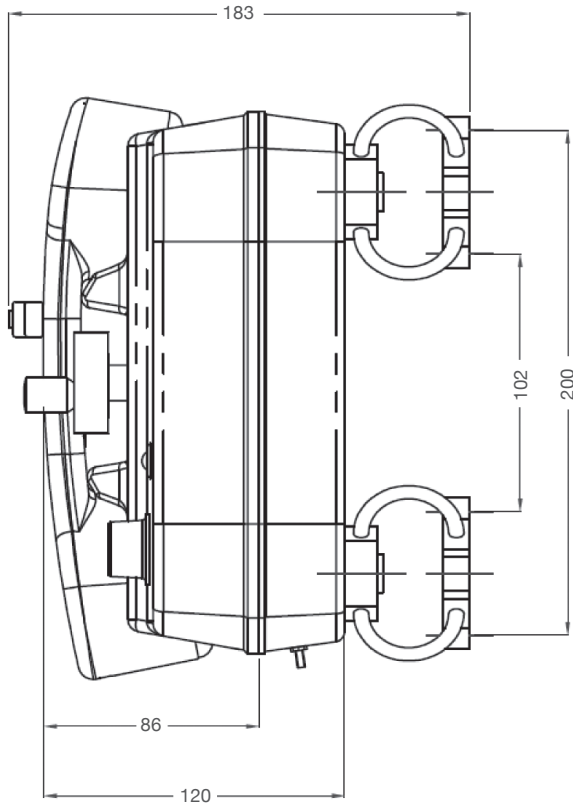

HOLES FOR MOUNTING

