

SELF POWERED TELEPHONE SYSTEM (BATTERYLESS)

ALARMS

TYPE: SCM-LD

MODEL: LD-98

(Flashing beacon alarm)

SCM
SISTEMAS



FEATURES

- Flashing beacon alarm.
- Suitable to use in noisy areas like engine room, etc.
- Material: ABS plastic.

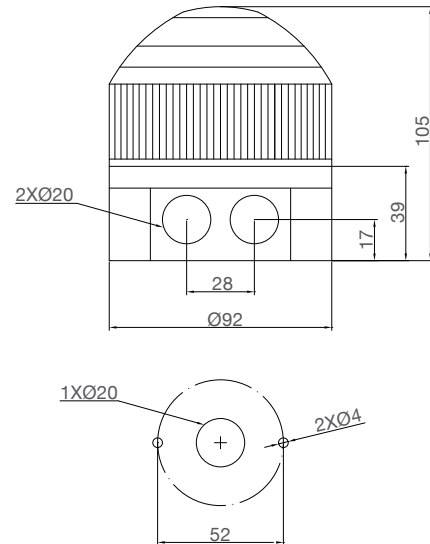

TECHNICAL SPECIFICATIONS

| | |
|-----------------------|----------------------------|
| Operation voltage | 24 VDC |
| Power consumption | 21 W |
| Flash frequency | Approx. 60-80 flash/min |
| Operating temperature | -20°C to +60°C |
| Relative humidity | Up to 95% (non condensing) |
| Weight | Approx 0.15 kg |
| IP-rating | 53 |