

# SELF POWERED TELEPHONE SYSTEM (BATTERYLESS)

## ALARMS

TYPE: SCM

MODEL: IS-MC1-R

(Ex proof acoustic and luminous alarm)

**SCM**  
SISTEMAS



### FEATURES

- Ex II 1G Ex ia IIC T4 Ga approved.
- Approved: SIRA 05ATEX2084X.
- LED 15cd.
- Dimension 95 x 88,70 x 116 mm.
- Acoustic/Luminous alarm.
- LED Flashing light.
- Color: ambar/red/blue.

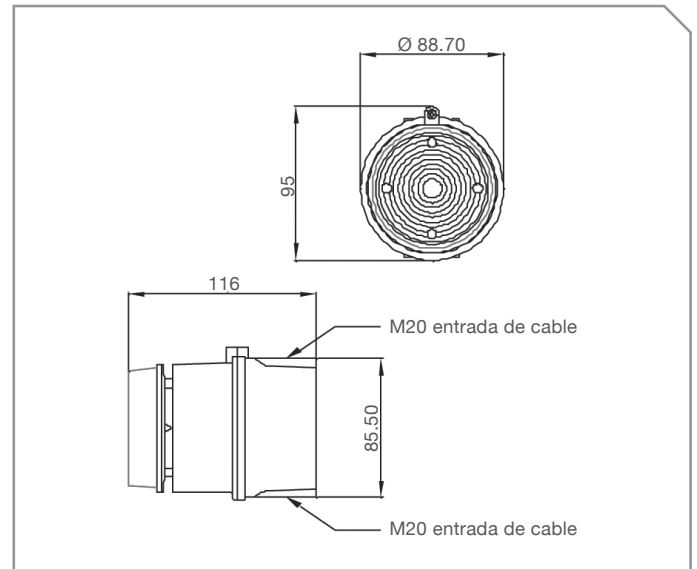

### TECHNICAL SPECIFICATIONS

Power supply	24 VDC
Power consumption	2.6 W max
Operating temperature	-20°C to +60°C
Relative humidity	Up to 95% (non condensing)
Weight	Approx 0.2 kg
IP-rating	65