

# SELF POWERED TELEPHONE SYSTEM (BATTERYLESS)

## TELEPHONES

TYPE: SCM-MAG

**MODEL: AU-MAG-MG-24**

**(Telephone with shock and vibration isolation)**

**SCM**  
SISTEMAS



### FEATURES

- Selfpowered telephone with shock and vibration isolation
- Excellent speech quality.
- 24 extensions selector switch.
- Material: ABS plastic (fireproof).
- Relay to activate additional devices incorporated in the circuit board.

### TECHNICAL SPECIFICATIONS

Operating temperature	-20°C to +50°C
Acoustic alarm	80 dB (1m)
Relative humidity	Up to 95% (non condensing)
Conversation time	20-30 min
Assembly	Bulkhead
Weight	Approx 4 kg
IP-rating	65
Resistive load	10A 250VAC / 30VDC
Inductive load	( $\cos\phi = 0.4$ ; L/R = 7 ms) 5A250VAC / 30VDC

# SELF POWERED TELEPHONE SYSTEM (BATTERYLESS)

TELEPHONES

TYPE: SCM-MAG

**MODEL: AU-MAG-MG-24**

**(Telephone with shock and vibration isolation)**

**SCM**  
SISTEMAS

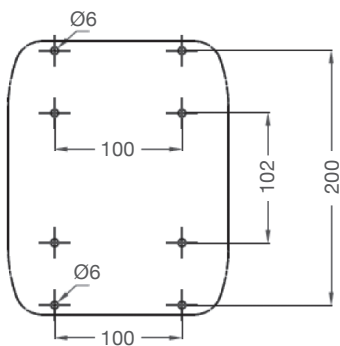
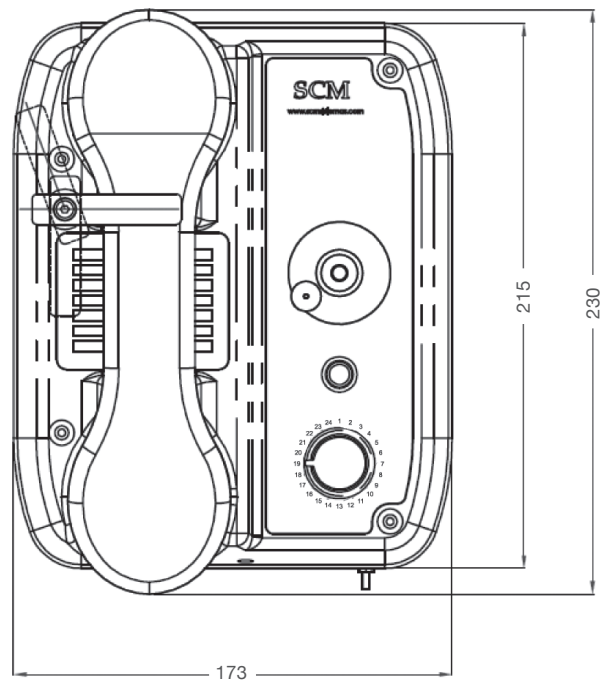
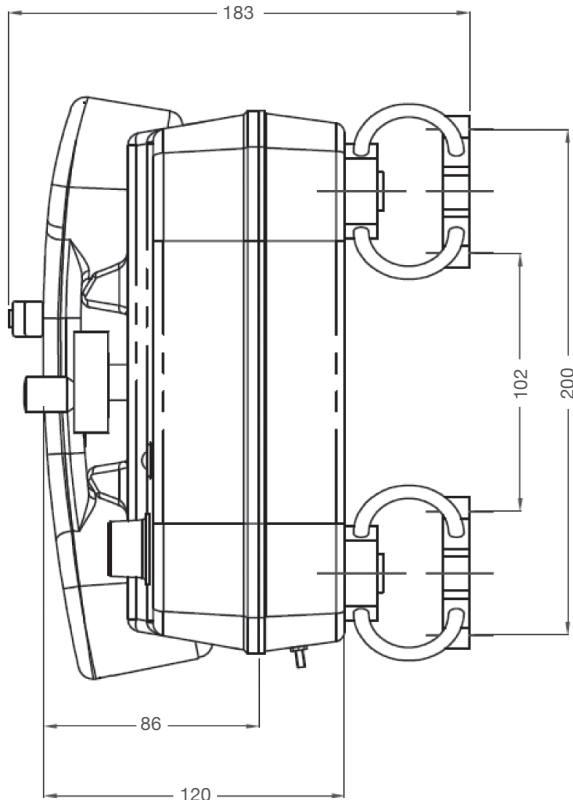

HOLES FOR MOUNTING

