

MAN

L49/60DF

Propulsion

The MAN 49/60DF is future-proof in multiple ways. Its benchmark fuel efficiency guarantees competitive vessel operation. The very low level of methane emissions ensures long-term CO₂ emission compliance. A modern engine platform with next-generation engine automation system can harness the benefits of a digitized marine operation. For this platform MAN Energy Solutions plans upgrades to future fuels.

Benefits at a glance

- Benchmark efficiency
- Robust performance in gas mode based on next-generation combustion control ACC 2.0
- Next-generation engine automation ready for future tasks such as cybersecurity
- Compact design by increased power density
- Very low methane emissions

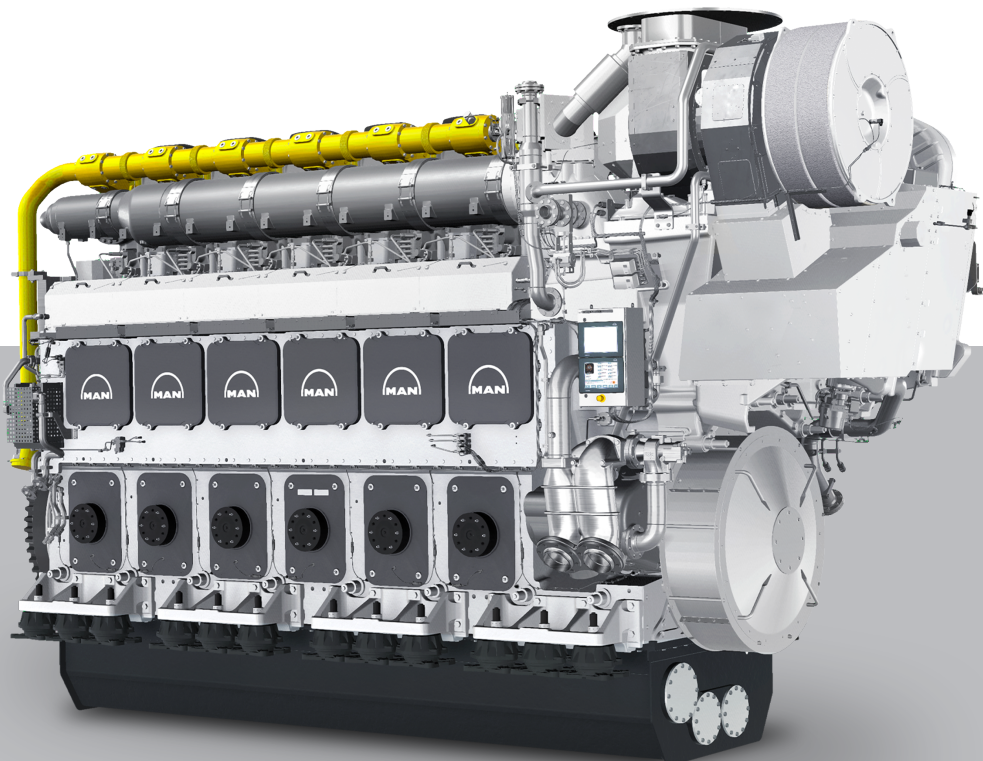

MAN L49/60DF

Propulsion

Dimensions

Cyl. No.		6L	7L	8L	9L	10L
L	mm	8,450	9,270	10,303	11,123	11,943
L ₁ *	mm	7,140	7,960	8,780	9,600	10,420
W	mm	3,160	3,160	3,160	3,160	3,160
H	mm	5,424	5,424	5,424	5,581	5,581
Dry mass	t	130	145	165	180	195

Output

Speed	rpm	600
mep	bar	23
MAN 6L49/60DF	kW	7,800
MAN 7L49/60DF	kW	9,100
MAN 8L49/60DF	kW	10,400
MAN 9L49/60DF	kW	11,700
MAN 10L49/60DF	kW	13,000

*L₁, flange of flywheel to front end of engine
Dimensions without flywheel protection cover
Minimum centerline distance for twin-engine installation: 3,700 mm

Last updated July 2022

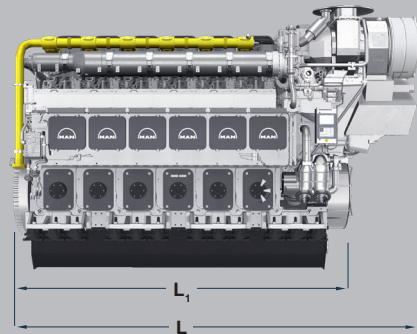
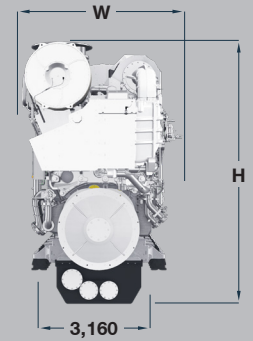

General

- Engine cycle: four-stroke
- No. of cylinders: 6L, 7L, 8L, 9L, 10L
- Bore: 490 mm – Stroke: 600 mm
- Swept volume per cyl: 113.14 dm³

Fuel consumption at 85 % MCR*

- Liquid fuel mode: 171.0g/kWh
- Gas mode: 6,990kJ/kWh

Cylinder output (MCR)

- At 600 rpm: 1,300 kW
- Power-to-weight ratio:
15.0 – 16.7 kW/kg

Compliance with emission regulations

- Gas mode: IMO Tier III
- Liquid mode: IMO Tier II,
IMO Tier III with MAN SCR-LP

Main features

Turbocharging system

- High efficiency MAN TCT and MAN TCX two-stage turbocharging system

Engine automation and control

- Next-generation in-house developed safety and control system MAN SaCoS 5000
- Next-generation combustion control

Fuel system

- Cylinder individual solenoid gas admission valves for gas injection into charge air
- Next-generation MAN Common Rail injection system for liquid main fuel or HFO, developed in-house
- Common rail pilot fuel oil system

Cooling system

- 2-string high and low temperature cooling water systems or alternatively a combined cooling water system

Starting system

- Starting air valves within cylinder heads

Engine mounting

- Resilient or rigid mounting

Optional equipment

- High torque variant for dredging applications rated at 1,200 kW/cyl
- Additional insulation for maximum surface temperature of 110 °C
- High levels of cybersecurity compliance
- Engine variant for methane numbers down to MN 60

MCR = Maximum continuous rating

SCR = Selective catalytic reduction

* According to IMO E2 test cycle, higher values for 8L and 10L, including pilot fuel oil

MAN Energy Solutions

86224 Augsburg, Germany

P + 49 821 322-0

F + 49 821 322-3382

info@man-es.com

www.man-es.com