

MAN

V51/60DF

Propulsion – High efficiency variant

Let your fuel take you further.
By combining diesel and gas technologies in one engine, the MAN 51/60DF gives you absolute fuel flexibility. There's no better way to keep your engine running effectively and economically. Full steam ahead.

Benefits at a glance

- Best-in-class fuel consumption in gas mode
- Robust performance in gas mode
- Self-learning combustion control
- High reliability and long TBOs
- Gas start capability
- Full power output down to MN70



MAN V51/60DF

Propulsion – High efficiency variant

Dimensions

| Cyl. No. | | 12 | 14 | 16 |
|----------------|----|--------|--------|--------|
| L | mm | 10,254 | 11,254 | 12,254 |
| L ₁ | mm | 9,088 | 10,088 | 11,088 |
| Dry mass | t | 191 | 222 | 248 |

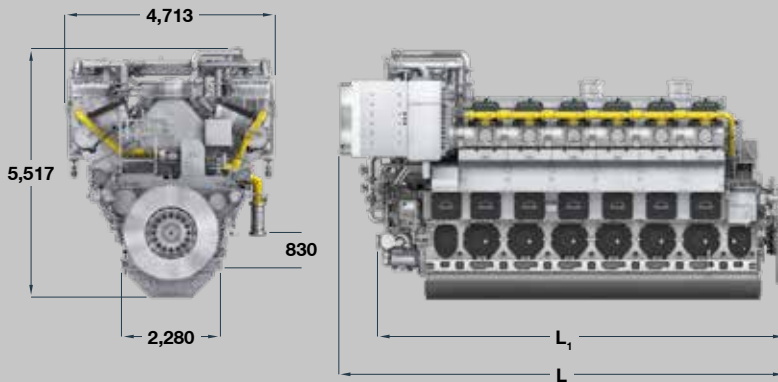

Output

| Speed | rpm | 514 | 500 |
|----------------|-----|--------|--------|
| mep | bar | 20.0 | 20.6 |
| MAN 12V51/60DF | kW | 12,600 | 12,600 |
| MAN 14V51/60DF | kW | 14,700 | 14,700 |
| MAN 16V51/60DF | kW | 16,800 | 16,800 |

Minimum centerline distance for twin engine installation: 4,800 mm
LHV of fuel gas $\geq 28,000$ kJ/Nm³
(Nm³ corresponds to one cubic meter of gas at 0 °C and 1.013 bar)

Last updated July 2022

General

- Engine cycle: four-stroke
- No. of cylinders: 12, 14, 16
- Bore: 510 mm – Stroke: 600 mm
- Swept volume per cyl: 122.6 dm³

Fuel consumption at 85 % MCR

- Liquid fuel mode: 175.5g/kWh
- Gas mode: 7,150kJ/kWh

Cylinder output (MCR)

- At 500/514 rpm: 1,050 kW
- Power-to-weight ratio: 14.8 – 15.2 kg/kW

Compliance with emission regulations

- IMO Tier II
- IMO Tier III (gas mode)
- IMO Tier III (diesel mode with MAN SCR-LP)

Main features

Turbocharging system

- High efficiency constant pressure MAN TCA series exhaust turbocharging system

Engine automation and control

- MAN in-house developed engine attached safety and control system MAN SaCoS_{one}

Air management

- Variable turbine area allowing improved adaption for diesel and gas mode operation while maintaining highest turbocharger efficiency over entire engine load

Fuel system

- Common rail pilot fuel injection system
- Conventional main injection system
- Variable injection timing for lowest fuel consumption while meeting IMO Tier II emission limits in diesel mode

Gas system

- Cylinder individual low pressure gas admission system, 5.7 bar(g) at inlet of gas valve unit

Cooling system

- 2-string high and low temperature cooling water systems

Starting system

- Starting air valves within cylinder heads

Engine mounting

- Resilient or rigid mounting

Optional equipment

- Gas start capability
- 100 % power take-off at engine free end available
- Variable inlet valve timing for improved combustion in part load operation

MCR = Maximum continuous rating
SCR-LP = Selective catalytic reduction (low pressure)

MAN Energy Solutions

86224 Augsburg, Germany
P + 49 821 322-0
F + 49 821 322-3382
info@man-es.com
www.man-es.com