

CLASSIC RUDDERS C SERIES

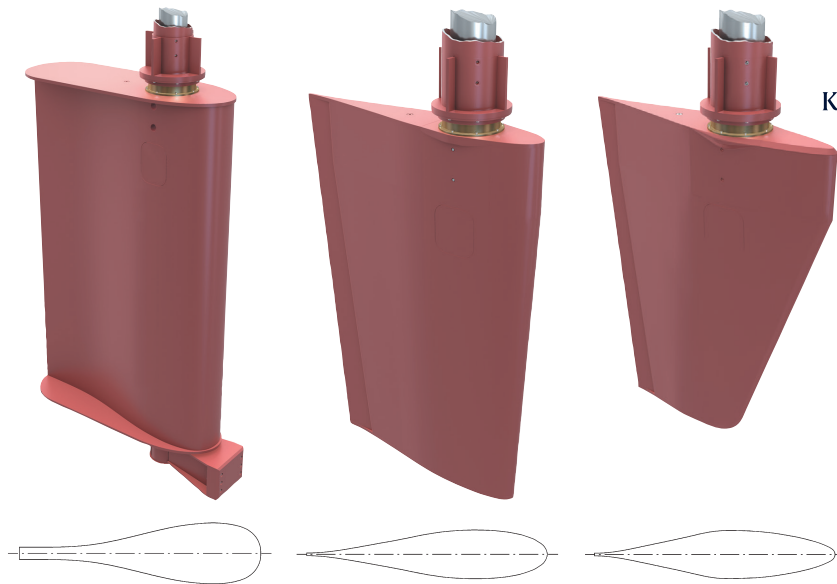

KONGSBERG



KONGSBERG CLASSIC RUDDERS - C SERIES

Rudders for all vessel speeds and configurations

Years of experience in ship design and hydrodynamics makes Kongsberg Maritime's expertise a skilled collaborator, also when special rudder designs are required.

Kongsberg Maritime classic rudders are based on well proven rudder profiles and offers reliability and safe operation in all sailing conditions. Standard solutions for easy installation and maintenance are applicable for most vessel speeds and aft ship configurations.

Three rudder profiles with different qualities and speed range match a wide range of vessels, such as merchant- and fishing vessels.

Also available, for other requirements, operation or configurations; Kongsberg Maritime flap rudders.

OPTIONS AVAILABLE

- Support type
 - Heel Pintle
 - Neck Bearing
 - Direct Trunk Support
- Lubrication system
 - Automatic or manual
- Seawater lubricated
- Cathodic corrosion protection
- Trunk with Steering Gear foundation
- Special rudder design on request
- Special bearings/liners
- Wire Guard
- Stainless steel liners

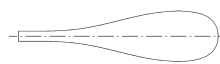

CB rudder for lower speed. Bulbous profile and large vane end-plates improves low speed manoeuvring. Heel module optional.



CM rudder for medium speed. Medium profile optimises the proportion between manoeuvrability and propulsive efficiency. Tapered or rectangular blade.



CS rudder for higher speed. Slim profile increases overall propulsive efficiency and reduces cavitation risk. Tapered blade, rounded corners and smooth surface.

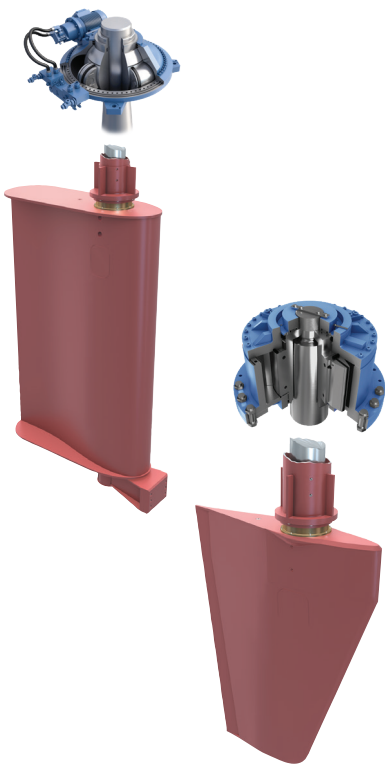

Rudder blade

Welded construction of certified steel and castings. Drain plugs of stainless steel. Lifting holes arranged.

Rudder trunk

Individually designed to fit hull structure and ease steering gear installation. Available solutions:

- Standard
- With SG foundation
- Extended

Rudder stock

Made to suit all steering gears. Both hydraulic and splined coupling to rudder, tested and approved by class society.

Bearing

Bronze and composite neck bearing with groves for grease lubrication.

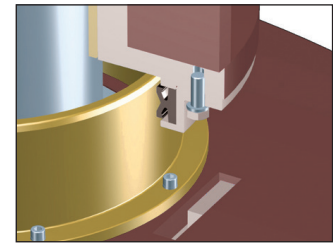
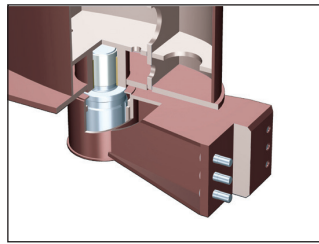

Heel module (optional)

Bolted flange connection to hull. Includes; pintle, housing, flange and bearing.

Sealing

Double sealing system with bronze seal-ring protects from grease leakage. Gaskets can be maintained and replaced at sea without loosening the rudder.

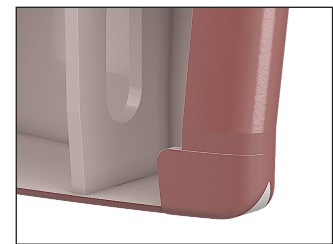
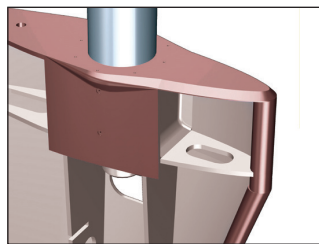
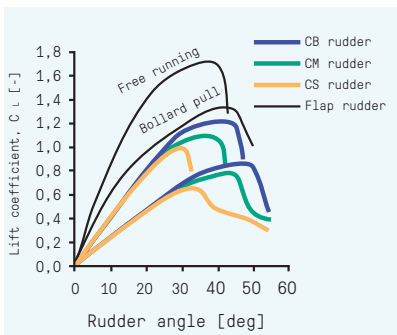

Cone block, casting

Hydraulic cone coupling between rudder- stock and blade. Eliminates stress concentrations in blade structure around rudder coupling.

Corner block, casting

Shaped with smooth curves to minimise cavitation risk. Cavitation may lead to severe erosion damages.

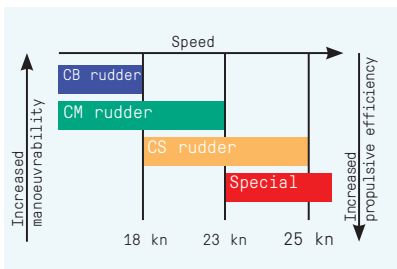

Basis of comparison:

- 1) Lift coefficient is dimensionless with mean propeller slipstream velocity.
- 2) Equal aspect-, taper- and thickness- ratio.
- 3) Rudder height equal to propeller diameter.
- 4) Rudder are placed in the propeller centre line.
- 5) Rudders are without vane end plates.

PRINCIPAL SPECIFICATION

Rudder support	spade or heel type
Rudder helm angle	no limit
Ice class	all
Speed range*	up to ~ 25 knots
Rudder balance	~ 27%
Rudder area	all sizes
Chord steps	1.3/1.5/1.7/1.9/2.2/2.5/2.9/3.3/3.8/4.3/4.9

(*for standard designs)

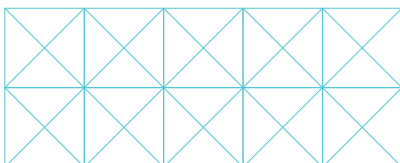

Kongsberg Maritime
P.O.Box 483, NO-3601
Kongsberg, Norway

Switchboard: +47 815 73 700
Global support 24/7: +47 33 03 24 07
E-mail sales: km.sales@km.kongsberg.com
E-mail support: km.support@km.kongsberg.com