

DESMI priming pump B114N

The DESMI priming pump is designed for mounting on non-selfpriming centrifugal pumps thus making the pump unit self-priming. In order to make the unit work, the delivery pipe has to be shut off, e.g. by means of a non-return valve.

The DESMI B114 priming pump is driven by its own electric motor. The suction side of the priming pump is connected to the suction side of the main pump by means of a pipe (C), a filter (D) and a non-return valve (H).

The filter (D) prevents solids from penetrating the priming pump, and the non-return valve (H) secures that back flow is avoided when the priming pump is stopped.

If the main pump has positive suction head the solenoid valve (E) stops water from running through the priming pump unexpected when the pump and priming pump are stopped.

The priming pump is provided with a supplementary tank (B) at the discharge side of the priming pump which has to be filled with water prior to starting the system. During priming, the air escapes while the water circulates in the pump procuring sealing and cooling.

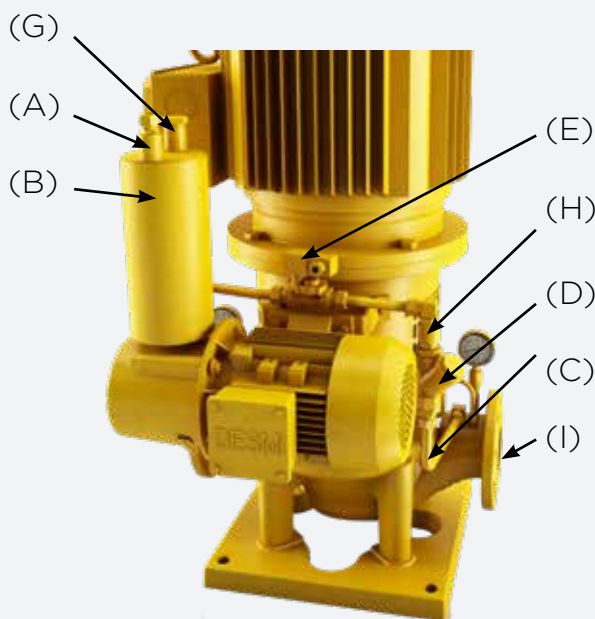

The pump is a priming pumps of the water ring type which can be fitted to a non-selfpriming pump.

- (A) Connection to drain
- (B) Supplementary tank
- (C) Connection to main pump suction
- (D) Filter
- (E) Solenoid Valve
- (F) Pressure switch
- (G) First fill connection
- (H) Non return valve
- (I) Suction side of pump
- (J) Discharge side of pump

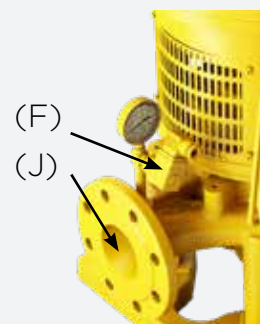

DESMI priming pump B114N

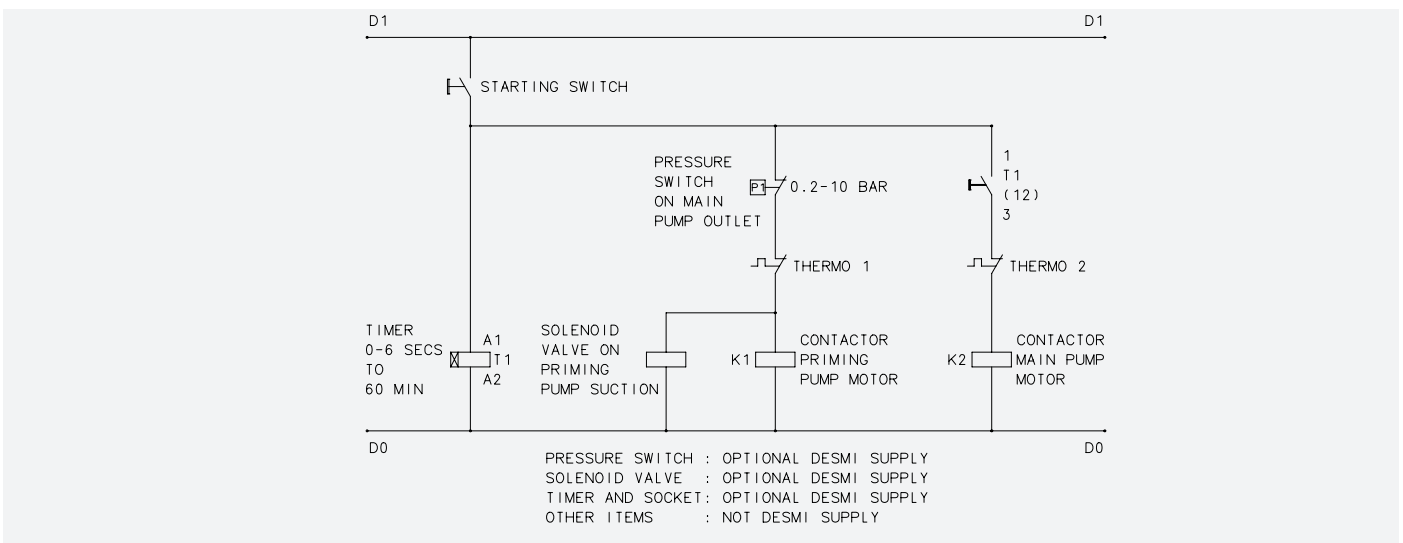

Performance Curves:

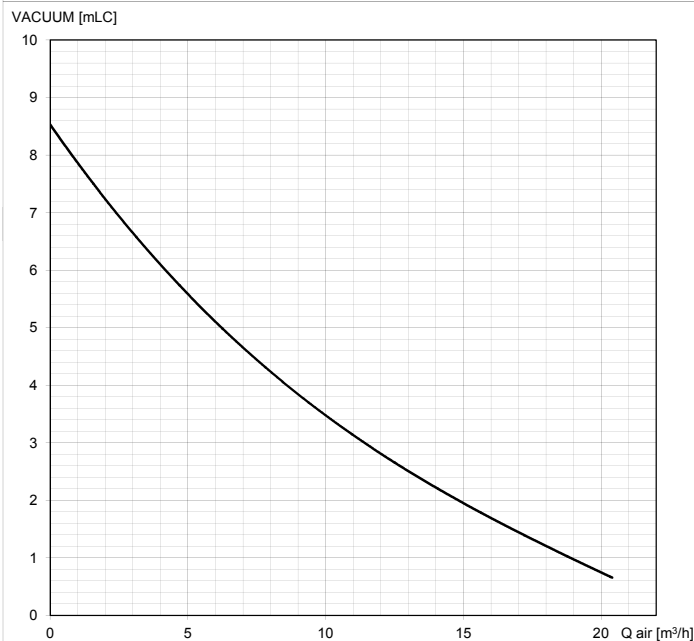
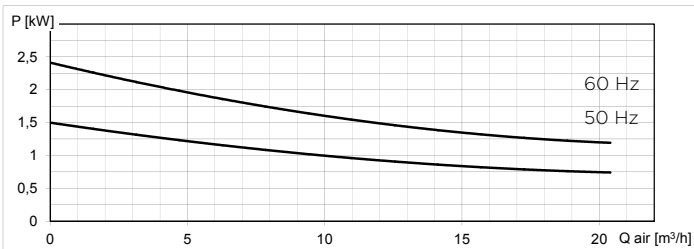

Performance Curve		Pump No.	-
Type	B114N	Item No.	-
rpm	50/60 Hz (2900/3410)	-	-
Impeller	ø112	Date	02-03-2006
Application	Priming Pump	Sign.	ST
Starting Current		I_a / I_n 7 A	

Functional Description:

When the starting switch is switched to ON, the timer T1 is supplied with a control current which activates it (see wiring diagram), also the solenoid valve will be activated together with the relay coil K1 which then activate the start of the priming pump motor.

When the time period set on the timer T1 expires, the switch T1 is ON, and the relay coil K2 to the main pump is activated by which the electric motor for the main pump is started up.

When the main pump produces a pressure above the value set on the pressure switch on main pump outlet, the current to the electric motor of the priming pump will be disconnected, and priming stops and the solenoid valve will close.

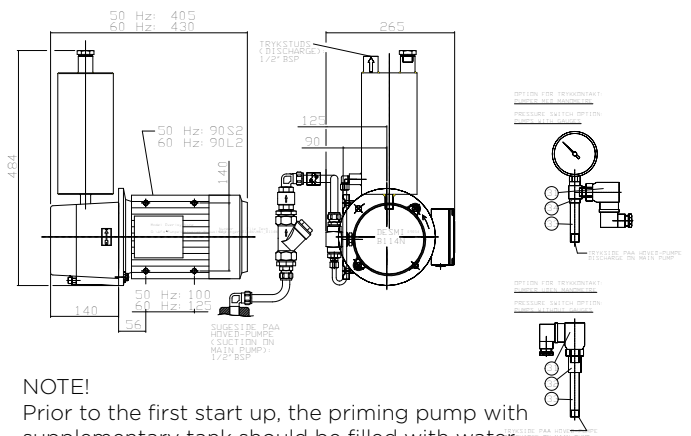

NOTE!

Prior to the first start up, the priming pump with supplementary tank should be filled with water.

Check that the direction of rotation is correct. Ensure that the filter or trap strainer is not clogged.

Voltage & Connections					
50 Hz	D (Delta)	220 - 240 V	60 Hz	D (Delta)	250 - 280 V
50 Hz	Y (Star)	380 - 420 V	60 Hz	Y (Star)	440 - 480 V

Max. water flow pumped to drain after completed priming : Approx. 25 liter/min for 50 Hz / approx. 33 liter/min for 60 Hz power supply. Depending on vacuum level and rpm during priming the water temperature in the pump can rise up to approx. 70°C/158°F within 20 minutes. Max. allowed water temperature in the pump is 80°C/176°F.