



Alfa Laval MIB 503

A compact solid bowl separator for marine & diesel applications

Introduction

MIB 503 is one of the smallest separators of Alfa Laval's solid bowl series. This product has been an upgrade of its predecessor, MIB 303, and has been developed to fulfill all requirements of the marine and diesel industry.

Application

This product has been designed for the removal of particles and water from distillate, marine diesel and lubricating oils. Removal of water and particles from mineral oil improves the reliability of the oil system. It also prevents serious wear and damages to the main engine.

Benefits

- Easy to install and start up
- Easy to operate and maintain
- High separation efficiency
- Robust and reliable design
- Lightweight materials
- Small footprint

Design

The separator consists of the frame housing, the separator bowl, the inlet and outlet device as well as the electric motor.

The frame housing is the part where the electric motor and the bowl are fitted. The motor can easily be accessed and inspected from a hatch. The hatch is located on the front part of the housing. The complete frame is sitting on rubber dampers which absorb all vibrations during operation.

The separator consists of a solids-retaining bowl which, depending on the application, can be used both as purifier or clarifier.

The MIB 503 is one extremely lightweight design. The outer parts of the bowl are manufactured in surface-coated aluminium and most of the inner parts i.e. the disc stack, the bottom disc and the inlet cone are manufactured in high-grade polymer composite.

The unique drive technology is based on an electric motor mounted directly to the bowl compared to conventional design of gear and belt systems.



Scope of supply

- Frame housing
- Separator bowl
- Inlet & outlet device
- Electric motor, direct driven
- Set of plates
- Documentation

Options

- Bowl conversion kit
- Service kits
- Set of tools

Working principle

The purifier operation takes place in the rotating solid-wall bowl. When the bowl is set as a purifier the uncleaned oil is fed into the bowl where the centrifugal force makes water and solid particles move out towards the periphery of the bowl, while the clean oil flows inwards.

To establish a water seal during start-up of the separator, water is added to the bowl before the oil feed is started. The

water collects in the water seal which drains into the water channel below the bowl.

The solids accumulate on the bowl wall and are removed periodically by hand. The cleaned oil flows towards the centre of the bowl and up to the paring disc. Since the oil is rotating, the stationary paring disc acts as a pump which forces the oil out through the outlet under pressure.

During the clarifier operation, the oil normally does not contain any free water. The separation principle is similar to the purifier, however there is no water seal, no water outlet and the water handling capacity is limited.

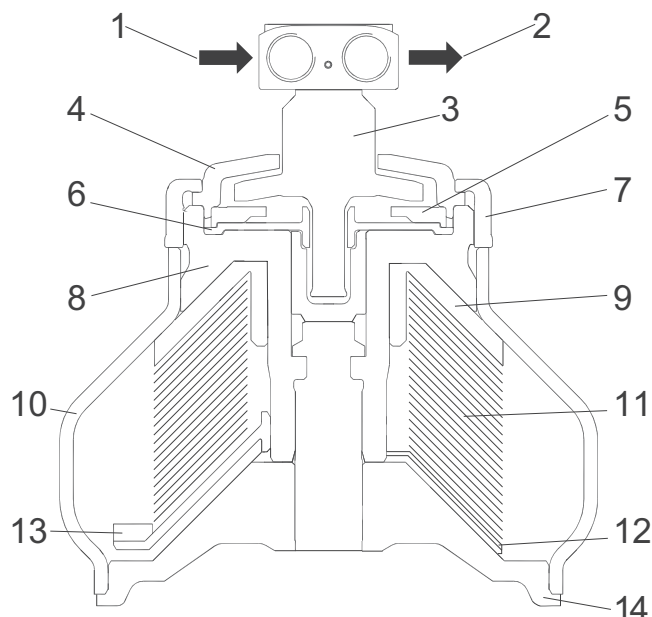

The MIB 503 section drawing is illustrating the basic parts of the separator bowl.

1. Inlet
2. Outlet
3. Paring disc
4. Paring disc chamber
5. Lever ring
6. Paring chamber lower
7. Lock nut
8. Centre rod
9. Inlet cone
10. Bowl wall
11. Bowl discs
12. Bottom disc (clarifier version)
13. Bottom disc (purifier version)
14. Bowl bottom

Technical data

Performance data

Hydraulic capacity ¹	1,25 m ³ /h (4,58 US gpm)
Separation temperature for distillate/ marine diesel oils	40°C
Separation temperature for lubricating oil ²	95°C
Maximum density	920 kg/m ³ at 15°C
Maximum motor power	0,45 kW (0,60 HP)
Sound pressure level	62 dB(A ₂)

¹ Actual capacities depend on operating conditions

² The maximum separation temperature of the separator

Connections

Feed inlet	ISO-G 3/8 inch
Light liquid phase outlet	ISO-G 3/8 inch
Heavy phase outlet	Ø 27 mm

Material data

Frame housing parts	Surface-coated aluminum
Separator bowl parts	Surface-coated aluminum, High-grade polymer composite
In and outlet parts	Surface-coated aluminum
Gaskets and O-rings	Fluorocarbon rubber (Viton®)

Weights (approximate)

Separator weight incl. bowl and motor	18 kg (39,7 lbs)
Bowl weight	4 kg (8,8 lbs)

Dimensional drawing

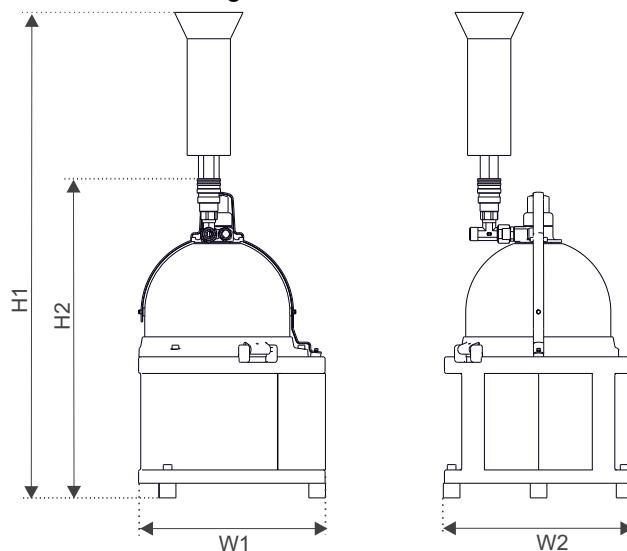

Dimensions

H1	Min. 729 mm (2 ft 4 11/16 inch)
H2	479 mm (1 ft 6 7/8 inch)
W1	280 mm (11 inch)
W2	280 mm (11 inch)

This document and its contents is owned by Alfa Laval Corporate AB and protected by laws governing intellectual property and thereto related rights. It is the responsibility of the user of this document to comply with all applicable intellectual property laws. Without limiting any rights related to this document, no part of this document may be copied, reproduced or transmitted in any form or by any means (electronic, mechanical, photocopying, recording, or otherwise), or for any purpose, without the expressed permission or authorized by Alfa Laval Corporate AB. Alfa Laval Corporate AB will enforce its rights related to this document to the fullest extent of the law, including the seeking of criminal prosecution.

How to contact Alfa Laval

Up-to-date Alfa Laval contact details for all countries are always available on our website at www.alfalaval.com